

OCTAGON BOXES
1-1/2" DEEP

RACO STEEL BOXES
& COVERS

Applications

- Octagon boxes are used in the installation of ceiling or wall lighting fixtures
- Extension rings provide a means for adding additional cubic capacity or as an outlet box for surface conduit

Product Features

- RACO® offers a variety of labor saving mounting brackets that allow for easy positioning of box along studs or joists
- See Box Selection section in the front of this catalog for complete description of bracket types and features
- Fixture bar hanger allows box to be located anywhere along length of bar
- RACO® 324 includes a 3/8" trade sized stud to accommodate fixture stem
- Combination screw heads provide for faster installation

Compliances

- – File E195978
- – File LR-1082 (128, 8128, 130)

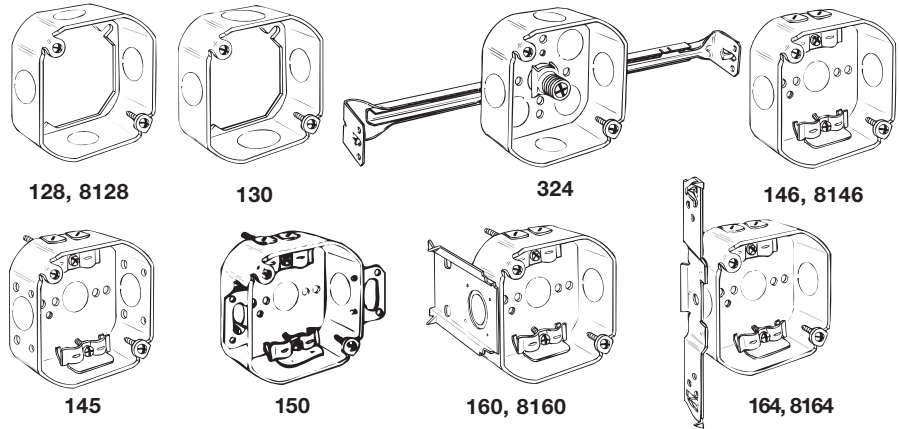

ORDERING INFORMATION - DIMENSIONS

4" OCTAGON EXTENSION RINGS – 1-1/2" DEEP – DRAWN WITH CONDUIT KO'S – 15.5 CUBIC INCHES					
CATALOG NUMBER	DESCRIPTION BRACKET & SETBACK	KNOCKOUTS		STD. PKG.	UPC BAR CODE
		SIDES COND.	BOTTOM COND.		
128	Extension ring	4-1/2"	—	50	—
8128	Extension ring	4-1/2"	—	25	
130	Extension ring	2-1/2", 2-3/4"	—	50	

4" OCTAGON WITH BAR HANGER – 1-1/2" DEEP – DRAWN WITH CONDUIT KO'S – 15.5 CUBIC INCHES							
CATALOG NUMBER	DESCRIPTION BRACKET & SETBACK	KNOCKOUTS		STD. PKG.	UPC BAR CODE	MAX. RECOMMENDED SUPPORT LOADS	
		SIDES COND.	BOTTOM COND.			CEILING FAN (DYNAMIC) LBS.	FIXTURE (STATIC) LBS.
324	3/8" Stud, adj. 14-1/4" to 22-1/2"	4-1/2"	4-1/2"	25		No	10*

*UL Rated at 50 lbs.

4" OCTAGON BOXES

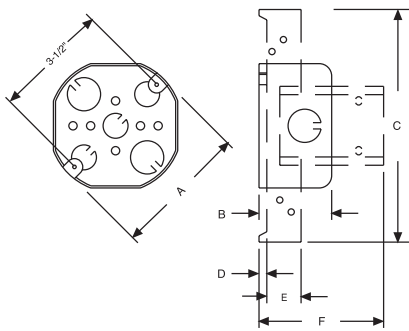

4" OCTAGON BOX – 1-1/2" DEEP – DRAWN WITH NONMETALLIC SHEATHED CABLE CLAMPS – 15.5 CUBIC INCHES								
CATALOG NUMBER	DESCRIPTION BRACKET & SETBACK	KNOCKOUTS			STD. PKG.	UPC BAR CODE	MAX. RECOMMENDED SUPPORT LOADS	
		SIDES		BOTTOM			CEILING FAN (DYNAMIC) LBS.	FIXTURE (STATIC) LBS.
		CABLE	COND.	COND.				
146	—	4	2-1/2"	1-1/2"	50	—	No	50
8146	—	4	2-1/2"	1-1/2"	50		No	50
145	Side holes, 1/8" & 1/4"	4	2-1/2"	1-1/2"	50	—	No	50
150	Ears	4	2-1/2"	1-1/2"	50		No	50
160	J brkt., 3/8" or 1/2"	4	2-1/2"	1-1/2"	50	—	No	50
8160	J brkt., 3/8" or 1/2"	4	2-1/2"	1-1/2"	50		No	50
164	TS brkt., 1/2"	4	1-1/2"	1-1/2"	50	—	No	50
8164	TS brkt., 1/2"	4	1-1/2"	1-1/2"	50		No	50

DIMENSIONS

CATALOG NUMBER	A	B	C	D	E	F
146, 8146	4"	1-9/16"	—	—	—	—
145	4"	1-9/16"	—	—	—	—
150	4"	1-9/16"	—	—	—	—
160, 8160	4"	1-9/16"	—	1/2"	—	3-1/8"
164, 8164	4"	1-9/16"	7-5/32"	1/2"	1-1/4"	—

